



CBU18DZBM

Wine Cellar service



Built-under counter

GENERAL INFORMATION

Number of bottles : 18

Number of zones : 2

Adjustable temperature range : 5-20°C

Noise level : 39dB

Energy class : F

Climate class : SN/ST (10-38)

Vinotag compatible : Yes

Product description

The wine cooler that enhances every tasting

With a width of just 30 cm, this built-in under-counter wine cooler is the ideal companion for wine lovers seeking elegance and performance in a compact format. Its two independent temperature zones allow red and white wines to be stored at their ideal temperatures, revealing the full richness of their aromas.

Designed with a plinth recess, it ensures discreet and seamless integration under the worktop, perfectly suited to contemporary kitchens. Its reversible matte black door delivers a modern look while offering flexible installation options, and compatibility with the Vinotag app allows you to manage your wine collection with precision. A perfect blend of technology and refinement for your finest wines.

MATTE FINISH DOOR

An elegant and contemporary design

DUAL TEMPERATURE ZONE

Store and refresh all your wines at the correct temperature in the same cellar

REVERSIBLE DOOR

Adapt the direction of opening of the door to easily install the cellar in the location of your choice

VINOTAG COMPATIBLE

Free wine cellar management application. Access a virtual representation of your cellar

CBU18DZBM

EAN-13 - 3595320108378

Capacity and Temperature

- **Number of bottles: 18**
 - Upper zone : 6
 - Lower zone : 12
- **Adjustable temperature: 5-20°C**
 - Upper zone : 5-20°C
 - Lower zone : 5-20°C

Door

Door color : Black
Door glass color : Grey
Number of glass layers : 3
Anti-UV : Yes
Low-e glass : Yes
Tempered glass : Yes
Reversible door : Yes
Handle type : Pulling bar
Door dimensions (WxDxH) : 28.9x5x71.4

Security

Alarm : Temperature
Child lock : Yes
Temperature memory : Yes

Logistic

Net dimensions (WxDxH): 29.5 x 57.0 x 82.0
Gross dimensions (WxDxH): 32.9 x 62.5 x 86.5
Net weight (kg) : 30.0
Gross weight (kg) : 32.0

Technical Data

Energy class : F
Annual energy (KWh/a) : 98
Climate class : SN/ST (10-38)
Noise level : 39dB / C
Energy Efficiency Index : 122 %
Power input : 140.00 W
Voltage : 220-240 V
Length of power cable : 150 cm
Type of gas : R600a
Gas charge : 18 g
Mainly recyclable product : Yes
Type of compressor : Standard
Main cooling system : Air moving system
Anti-vibration system : Yes
Adjustable feet : 4 / 1.5 cm

Light

Light source : LED
Light color(s) : White
Dimmable light : no
Light switch : yes
Permanent light option : Yes

Qty per 20' : 144
Qty per 40' : 304
Qty per 40 HC : 397
Customs code :

CBU18DZBM

EAN-13 - 3595320108378

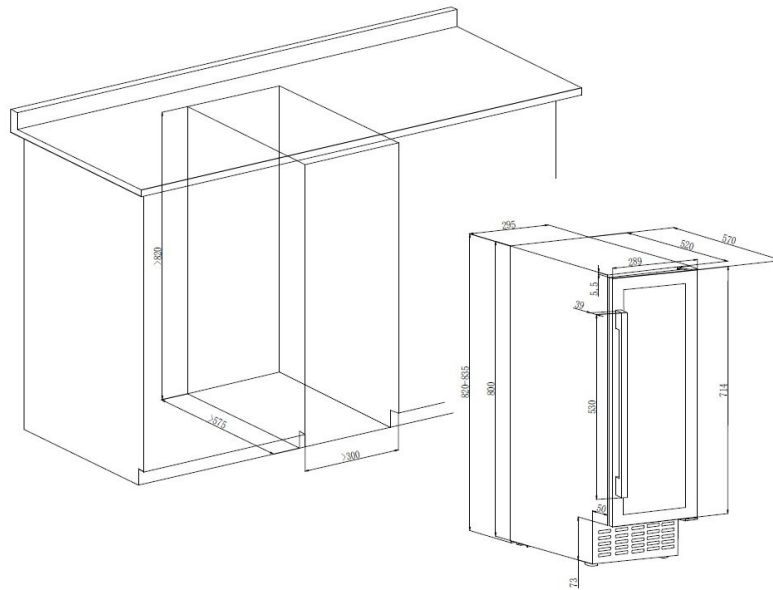

Accessories

- 4 shelves, wooden, sliding

Built-in information

Built-in dimensions (WxDxH) : 30.00 x 57.50 x 82.00

Plumbing passage : No

Recessed plinth : Yes / 5.00

Plinth height : 7.60

Installation warning : This product is equipped with a front ventilation system. Follow the installation instructions to ensure proper operation of the unit.