



## CBU50DZBM

Wine Cellar service

Built-under counter



### GENERAL INFORMATION

**Number of bottles : 46**

**Number of zones : 2**

**Adjustable temperature range : 5-20°C**

**Noise level : 39dB**

**Energy class : F**

**Climate class : SN/ST (10-38)**

**Vinotag compatible : Yes**

### Product description

Elevate your kitchen with our 60 cm built-under built-in wine cellar, designed for those who appreciate both style and precision. Its seamless door with an integrated handle blends effortlessly into modern cabinetry, creating a refined and minimalist look.

Featuring dual temperature zones, this cellar allows you to store and serve red and white wines at their optimal conditions simultaneously. Advanced climate control, low-vibration technology, and gentle LED lighting ensure your bottles are preserved with the utmost care.

For added convenience, each shelf is mounted on telescopic rails, allowing smooth, effortless access to your bottles while keeping your collection perfectly organized.

Compact yet spacious, it fits perfectly under the counter while offering easy access to your finest wines. A premium solution that combines convenience, sophistication, and professional-quality storage—right at home.

#### **MATTE FINISH DOOR**

An elegant and contemporary design

#### **DUAL TEMPERATURE ZONE**

Store and refresh all your wines at the correct temperature in the same cellar

#### **REVERSIBLE DOOR**

Adapt the direction of opening of the door to easily install the cellar in the location of your choice

#### **VINOTAG COMPATIBLE**

Free wine cellar management application. Access a virtual representation of your cellar

# CBU50DZBM

EAN-13 - 3595320108385

## Capacity and Temperature

- **Number of bottles: 46**
  - Upper zone : 16
  - Lower zone : 30
- **Adjustable temperature: 5-20°C**
  - Upper zone : 5-20°C
  - Lower zone : 5-20°C

## Door

**Door color :** Black  
**Door glass color :** Grey  
**Number of glass layers :** 3  
**Anti-UV :** Yes  
**Low-e glass :** Yes  
**Tempered glass :** Yes  
**Reversible door :** Yes  
**Handle type :** Pulling bar  
**Door dimensions (WxDxH) :** 58.9x5x71.4

## Security

**Alarm :** Temperature  
**Child lock :** Yes  
**Temperature memory :** Yes

## Logistic

**Net dimensions (WxDxH):** 59.5 x 57.0 x 82.0  
**Gross dimensions (WxDxH):** 66.0 x 62.5 x 88.0  
**Net weight (kg) :** 47.0  
**Gross weight (kg) :** 51.0

## Technical Data

**Energy class :** F  
**Annual energy (KWh/a) :** 105  
**Climate class :** SN/ST (10-38)  
**Noise level :** 39dB / C  
**Energy Efficiency Index :** 122 %  
**Power input :** 200.00 W  
**Voltage :** 220-240 V  
**Length of power cable :** 150 cm  
**Type of gas :** R600a  
**Gas charge :** 35 g  
**Mainly recyclable product :** Yes  
**Type of compressor :** Inverter  
**Main cooling system :** Air moving system  
**Charcoal filter :** 1  
**Anti-vibration system :** Yes  
**Adjustable feet :** 4 / 1.5 cm

## Light

**Light source :** LED  
**Light color(s) :** White  
**Dimmable light :** no  
**Light switch :** yes  
**Permanent light option :** Yes

**Qty per 20' :** 54  
**Qty per 40' :** 114  
**Qty per 40 HC :** 170  
**Customs code :**

# CBU50DZBM

EAN-13 - 3595320108385

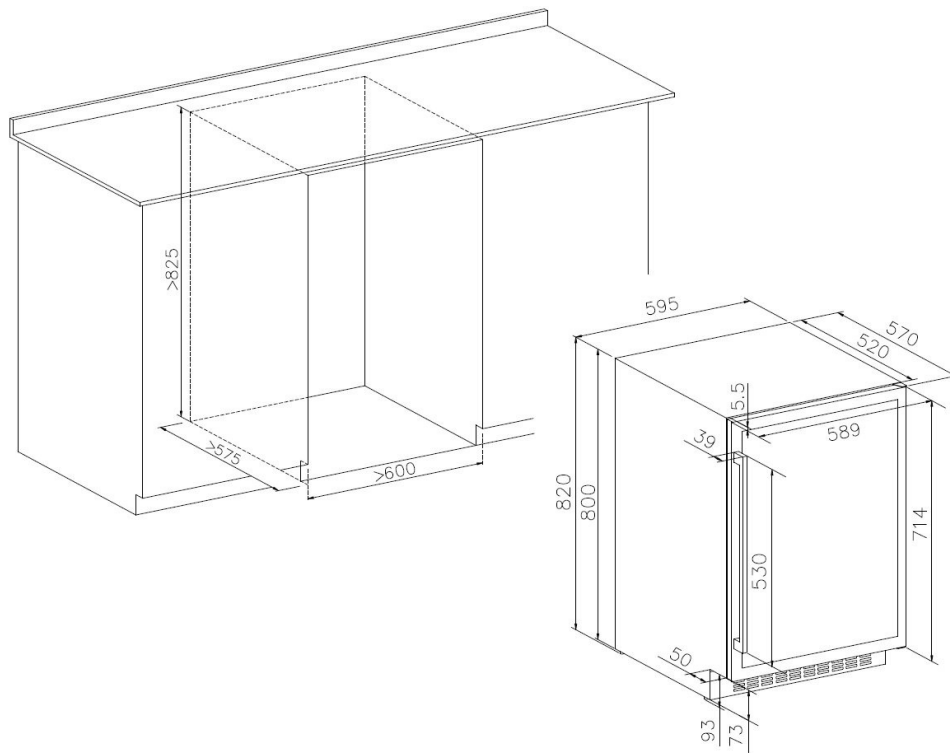

## Accessories

- 5 shelves, wooden, sliding, rails
- 1 charcoal filter, (FILTRE5)

## Built-in information

**Built-in dimensions (WxDxH) :** 60.00 x 57.50 x 82.50

**Plumbing passage :** No

**Recessed plinth :** Yes / 5.00

**Plinth height :** 7.30

**Installation warning :** This product is equipped with a front ventilation system. Follow the installation instructions to ensure proper operation of the unit.