

VISTA FRONTALE
FRONT VIEW

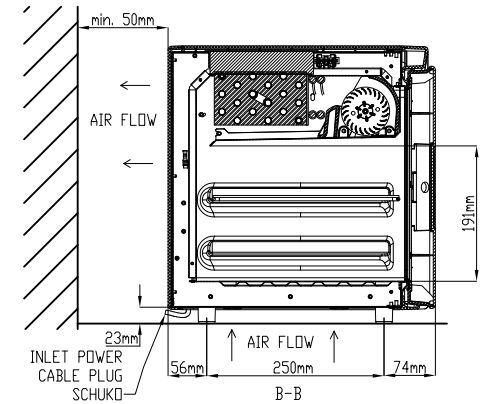

VISTA LATERALE SEZIONE B-B
SIDE VIEW B-B SECTION

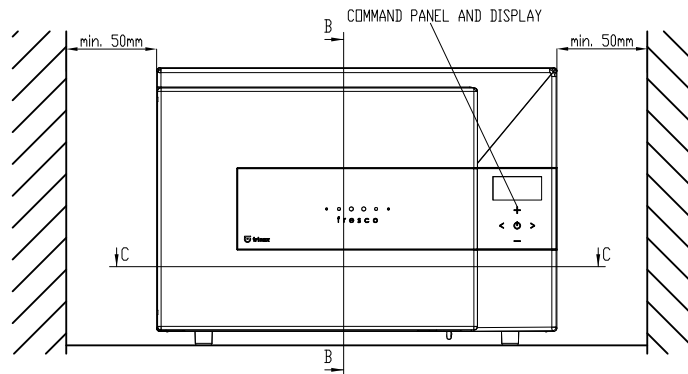

VISTA DALL'ALTO
TOP VIEW

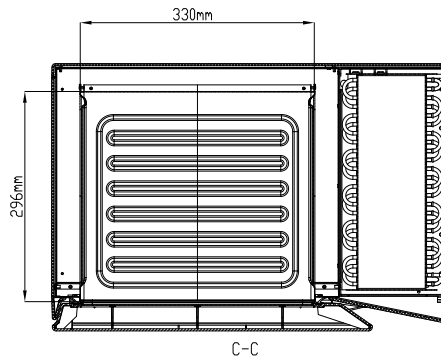

SEZIONE C-C
C-C SECTION

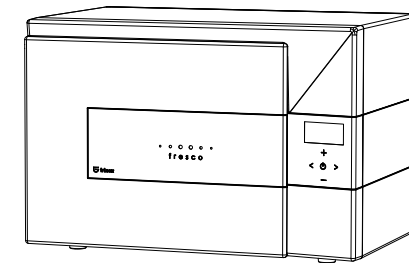

VISTA ASSONOMETRICA
AXONOMETRIC VIEW

Technical data:	
Yield for blast chilling cycle: (90/+3°C)	2,5Kg a 32°C
Yield for shock freezing cycle: (90/-18°C)	2,5Kg a 32°C
Trays capacity n.2 GN1/2 H40mm	2
Electric supply	220-240Vac 50Hz
Total rating	310W
Full load amps	2,12A
Gas type / Gas charge	R290 / 45g
Climatic class	T (18°C + 43°C)
Net weight	29Kg

DATI TECNICI
TECHNICAL DATA

H			
G			
F			
E			
D			
C			
B			
A			
O	PRIMA EMISSIONE	19.08.2020	
NR	MODIFICA	ESEGUITO	APPROVATO

MATERIALE	DIMENSIONI	TRATTAMENTO	DESCRIZIONE
-	-	-	FRESCOIII
		SCALA	GRUPPO
		TOLLERANZE GENERALI ISO 2768-mK	
			NOME FILE: PATH

QUESTO DISEGNO E' DI NOSTRA PROPRIETA' E NON PUO' ESSERE USATO O RIPRODOTTO SENZA NOSTRA AUTORIZZAZIONE